



ECOTRACK
equipment

Electric Telescopic Front End Wheel Loader ELT 1320

Zero Emissions !!
All the Power
Without the Fumes



ELT 1320



MAINTENANCE



CONSTRUCTION



FARM & COUNTRY

Zero emissions. Clean is in. Join the electric revolution. 

www.ecotrackequipment.com



ELT 1320

Environmentally Friendly. All Electric. No Fumes. No Diesel. Inexpensive to Run.

At EcoTrack, we know that people are looking for more affordable and efficient ways to work the land and to be independent. We are committed to leading the charge in Electric sustainability with our Electric Loaders.



TELESCOPIC - ELT 1320



Zero emissions. Clean is in. Join the electric revolution. 

www.ecotrackequipment.com



Easy to Use. Simple to Operate.

All Wheel Direct Drive. No Diesel Motor. No Transmission.

All Wheel Drive (AWD) ELECTRIC DRIVE

Two independent electric motors deliver power directly to two axles. Each motor drives two wheels.

FRONT ELECTRIC DRIVE MOTOR

Direct drive motor powers the front axle.

2 WHEELS PER AXLE

Each axle is rigidly connected to two wheels, driven by its motor.

STANDARD INDUSTRIAL 72V LEAD-ACID TRACTION BATTERY SYSTEM (LITHIUM OPTIONAL)

Reliable and proven battery system delivers consistent power for motors and all vehicle systems.

REAR ELECTRIC DRIVE MOTOR

Direct drive motor powers the rear axle.

ELT 1320



Zero emissions. Clean is in. Join the electric revolution. 

www.ecotrackequipment.com

ELT 1320



What Is Articulation?

Articulation in a loader refers to a steering design where the machine pivots at a central joint, allowing the front and rear sections to bend relative to each other instead of relying on wheel-only steering. This design allows all four wheels to follow nearly the same path during turns, greatly reducing turf damage compared to skid steers that depend on tire scrubbing. Rather than tearing or scuffing the ground, the tires mainly compress the surface, leaving only light temporary impressions. This makes articulating loaders ideal for use on grass, landscaped areas, estates, golf courses, and other finished surfaces where appearance matters.

Articulation also provides a smoother and more controlled operating experience. Because the machine steers through its center, operators can maneuver accurately while minimizing disturbance to surrounding areas. This is especially useful when working near buildings, trees, fences, or delicate landscaping where precision is important. The design also helps keep the attachment aligned with the direction of travel, improving control when handling materials such as soil, mulch, pallets, or snow.

Another major advantage is reduced restoration and maintenance costs. By minimizing surface disturbance, operators can complete jobs without extensive lawn or ground repairs afterward, saving both time and money while maintaining a clean, professional appearance.



Others

Zero emissions. Clean is in. Join the electric revolution. 

www.ecotrackequipment.com

The Benefits of Articulation

The EcoTrack articulated design ensures that all four wheels follow nearly the same path when turning, which greatly reduces turf damage compared to skid steers that rely on tire scrubbing. As a result, articulating loaders are especially well-suited for use on grass, landscaped areas, and other finished surfaces where minimizing ground disturbance is critical.

In addition to being more surface-friendly, articulation provides a tighter turning radius, making the machine highly maneuverable in confined spaces such as residential properties, barns, and job sites with obstacles. It also improves traction, as the tires maintain forward motion rather than skidding, which is beneficial on soft, wet, or uneven ground.

Furthermore, articulating loaders offer better control and stability when handling loads, since the front frame and attachment remain aligned with the direction of travel.



Zero emissions. Clean is in. Join the electric revolution. 

www.ecotrackequipment.com



ELT 1320

Rethinking Runtime: Here is why 5 or 6 Hours Is More Than Enough for Real-World Work

Many people initially question the operating time of an electric front-end loader, but in reality, this concern is often more psychological than practical. Some imagine nonstop operation that rarely occurs in the real world. Unlike a passenger vehicle driving long distances on a highway, a loader operates in cycles throughout the day. Operators stop regularly to reposition materials, adjust loads, inspect work areas, speak with coworkers, open gates, take lunch breaks, use the washroom, and move between tasks. Very few operators can physically sit and operate a loader continuously for five straight hours without interruption or taking a break.

In real-world applications such as landscaping, farming, snow removal, property maintenance, and light construction, the actual active operating time is often far lower than customers initially assume. For many users, an electric loader with approximately five hours of runtime is more than sufficient to complete a full day's work. In addition, charging opportunities naturally occur during breaks and downtime. Simply plugging the machine in during lunch or between jobs can provide additional operating time and further extend productivity.

Once customers experience electric equipment firsthand, many realize that runtime concerns are often overstated, while the real benefits — quiet operation, lower maintenance, zero emissions, and reduced operating costs — become far more valuable in everyday use.

Runtime and Charge Comparison - Two Options

Standard Maintenance Free Lead Acid Batteries



Lead Acid Batteries - ELT 1320

Working Time	6 hours
Charging Time	8 hours

Optional Maintenance Free Lithium Batteries



Lithium Batteries - ELT 1320

Working Time	7.5 hours
Charging Time	5 hours

Zero emissions. Clean is in. Join the electric revolution. 

www.ecotrackequipment.com

Specifications - ELT 1320

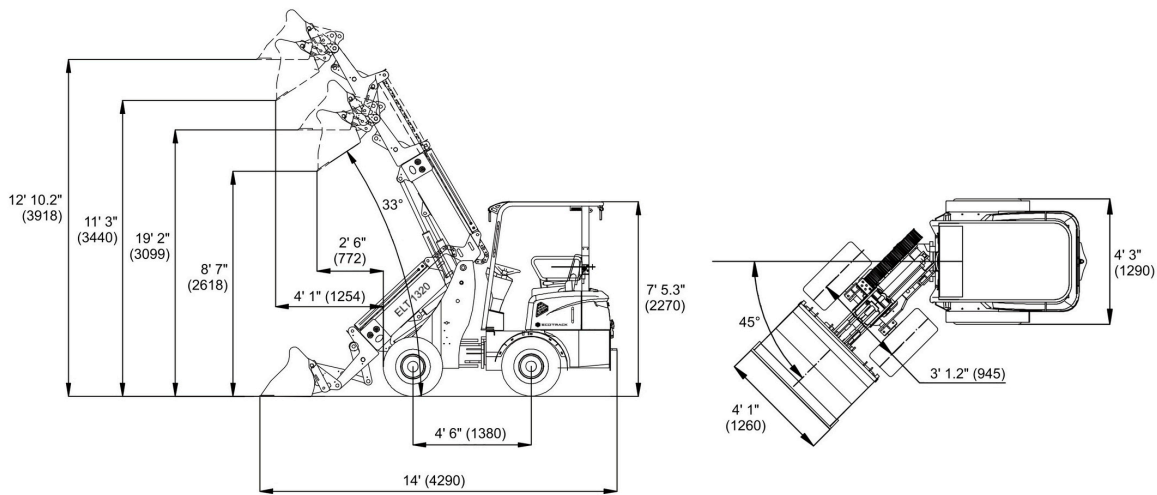

Dimension are subject to change without notice.

ITEM /STANDARD	IMPERIAL	METRIC
Rated Load	1,320 lbs	600 kg
Bucket Capacity	2.2 sq ft	0.2 sq mt
Fuel Type	Electric	Electric
Working Time	5 hours	5 hours
Working Speed (low / high)	6 / 12 mi/h	10 / 20 km/h
Towing Capacity	9,200 lbs	4,200 kg
Wheel Base	4' 6"	1,380 mm
Minumim Ground Clearance	8"	200 mm
Battery Quantity	4	4
Battery Capacity	25.4 kWh	25.4 kWh
Rated Voltage	72 V	72 V
Drive System Voltage	70 V	72 V
Drive System Power	11 HP	8 kW
Motor Quantity	2	2
Tire Type	26 x 12 -12	26 x 12 -12
Overall Dimensions L x W x H)	12'6" x 4'1" x 7'5"	4290 x 1260 x 2270 mm
Overall Weight	4,784 lbs	2,170 kg
Standard Battery Type	Maint. Free Lead Acid	Maint. Free Lead Acid
Optional Battery Type	Lithium	Lithium

Specifications are subject to change without notice.

Zero emissions. Clean is in. Join the electric revolution. 

www.ecotrackequipment.com

Full Range of Quick Hitch Attachments

BUCKETS

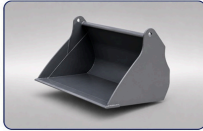

General Purpose Bucket



Clamshell Bucket (4 in 1 Bucket)



Screening Bucket

GRAPPLES & FORKS

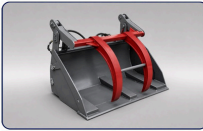

Grapple Bucket (Hydraulic)



Hydraulic Log / Root Grapple (Timber / Bush Grapple)



Silage Grapple (Hydraulic)



Hay Fork



Drum Clamp (Hydraulic)

FORKLIFT

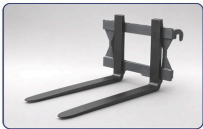

Pallet Forks

SNOW REMOVAL



V-Plow Snow Blade (Hydraulic)



Snow Plow (Hydraulic)

CONSTRUCTION & MAINTENANCE



Backhoe Attachment (Hydraulic)



Auger Drive (Hydraulic)



Angle Broom (Hydraulic)



Dozer Blade (Hydraulic)

QUICK HITCH SYSTEM

Replace a non-hydraulic attachment in only 30 seconds without getting off the front end loader. Replace a hydraulic attachment in only 60 seconds with no tools.

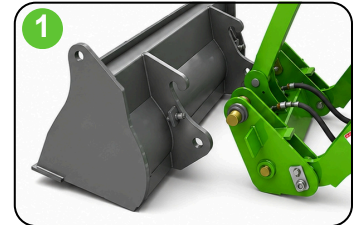

Drive up to the attachment



Lift the loader boom



Continue to lift until connected



Engage the lock



ECOTRACK
equipment



Zero Emissions.
All the Power
Without the
Fumes.



226-568-7063



ecotrackequipment.com



580303 Side Road 60, Berkeley,
Ontario, Canada N0H 1C0